

2

1

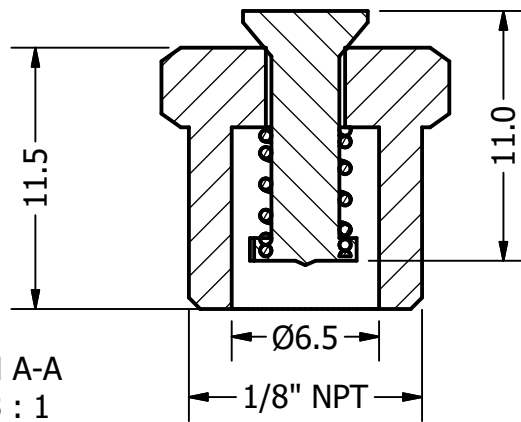
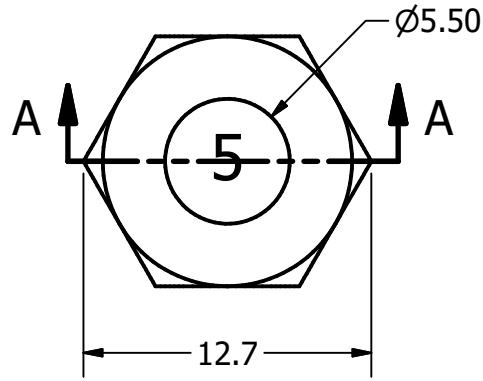

SECTION A-A  
SCALE 3 : 1

**NOTES:**

- Free of burrs and swarfs
- No particles (greater than 0.2mm)
- No Sharp Edges

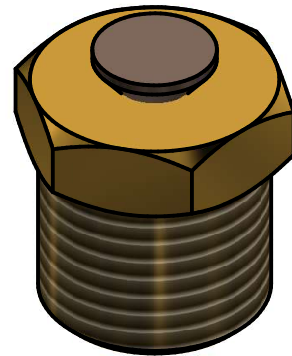
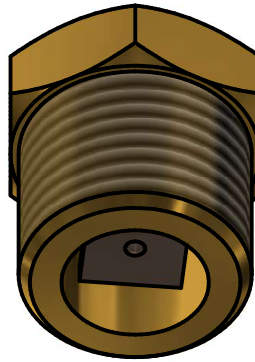

PART NUMBER				DIMENSIONING AND TOLERANCING PER ASME Y14.5M-1994		ALL DIMENSIONS [mm.]		SCALE: 3 : 1		MAT: Brass / Steel	
901015											
				DEPT	DATE	NAME		 H.T.L perma USA, L.P. 2129 Center Park Road Charlotte, NC 28217 (704) 377-3100			
				A.E.	6.26.2018	K. Brooks					
				PROJECT				DESCRIPTION:			
				Accessories				Relief Valve 1/8" NPT male [5 lbs]			
								<div style="font-size: 2em; font-weight: bold;">1</div> <div style="font-size: 3em; font-weight: bold;">A</div>			
STATUS		REVISION		DATE		NAME		PREV DWG NUM:		DWG NUM: AX_SPF_015_A	

2

1