

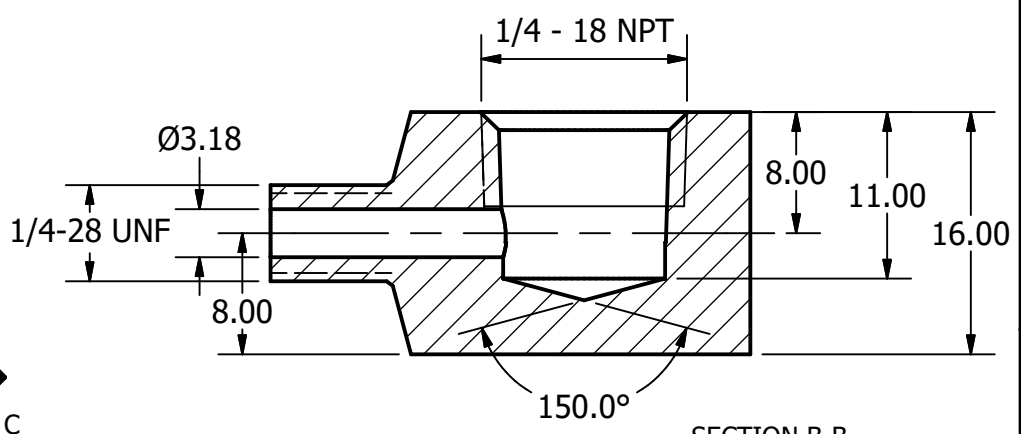

SECTION C-C
SCALE 2 : 1

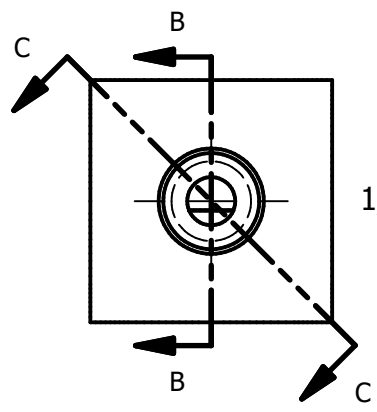
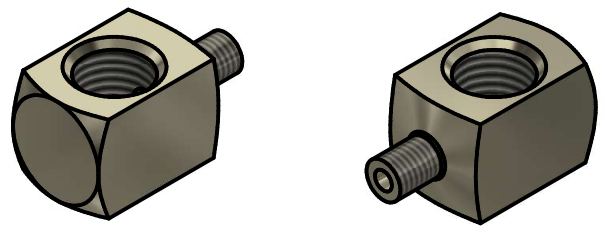

SECTION B-B
SCALE 2 : 1

- NOTES:**
- Free of burrs and swarfs
 - No particles (greater than 0.2mm)
 - No Sharp Edges



PART NUMBER		DIMENSIONING AND TOLERANCING PER ASME Y14.5M-1994		ALL DIMENSIONS [mm.]	SCALE: 2 : 1	MAT: Nickel Plated, 12L14 C.S.
901028						
		DEPT	DATE	NAME	 H.T.L perma USA, L.P. 2129 Center Park Road Charlotte, NC 28217 (704) 377-3100	
		A.E.	3.21.18	K. Brooks		
		PROJECT			DESCRIPTION:	1 A
		Accessories			Angle 90, 1/4"-28 UNF-M X 1/4" NPT-F	
STATUS	REVISION	DATE	NAME	PREV DWG NUM: AX_ANG_028_C	DWG NUM: AX_ANG_028_D	