

2

1

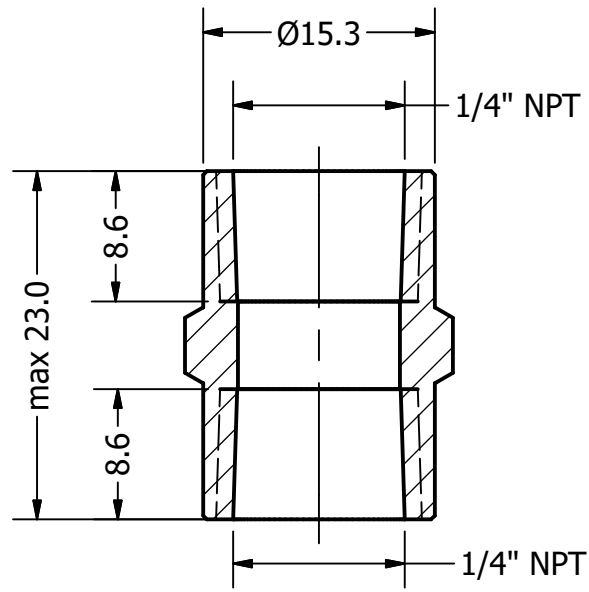

SECTION B-B  
SCALE 2 : 1

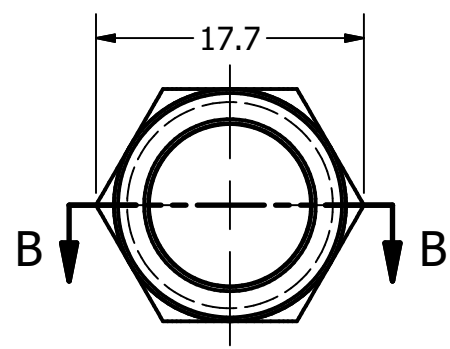

**NOTES:**

- Free of burrs and swarfs
- No particles (greater than 0.2mm)
- No Sharp Edges



PART NUMBER				DIMENSIONING AND TOLERANCING PER ASME Y14.5M-1994		ALL DIMENSIONS [mm.]		SCALE: 2 : 1		MAT: Brass	
901013											
				DEPT	DATE	NAME		 H.T.L perma USA, L.P. 2129 Center Park Road Charlotte, NC 28217 (704) 377-3100			
				A.E.	6.26.2018	K. Brooks					
				PROJECT				DESCRIPTION:		<div style="font-size: 2em; font-weight: bold;">1</div> <div style="font-size: 2em; font-weight: bold;">A</div>	
				Accessories				Coupler 1/4" NPT female			
STATUS	REVISION	DATE	NAME	PREV DWG NUM: AX_SPF_013_A				DWG NUM: AX_SPF_013_B			

2

1